

This is a controlled document.

Hardcopy to be endorsed by authorized person.
Check with Issuing Office or SAP system for latest update.

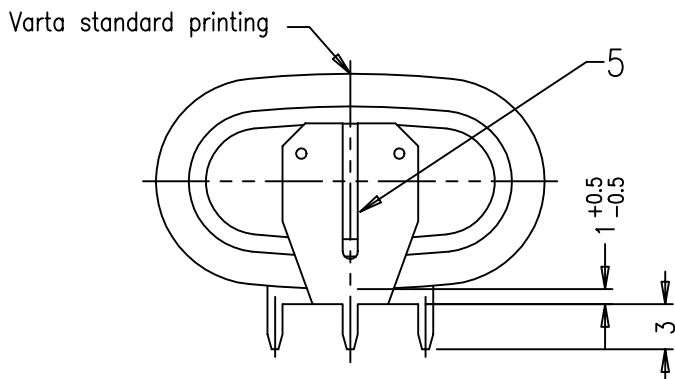
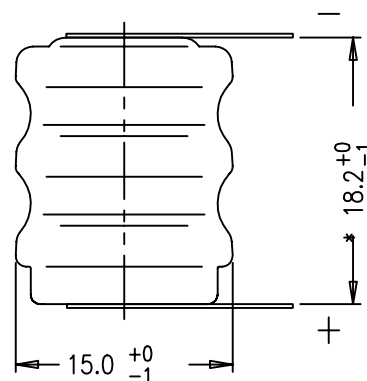
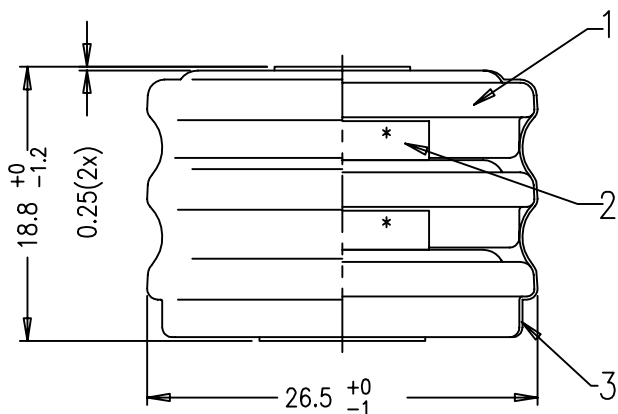
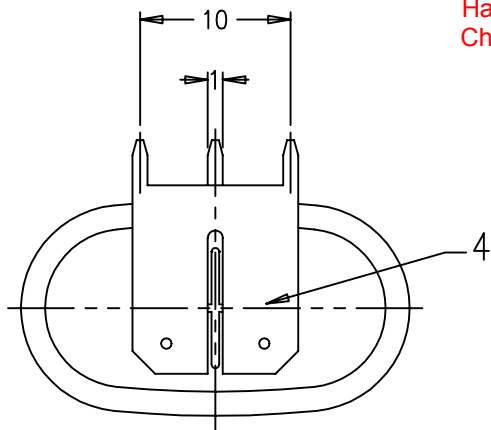

- Note: 1) No welding onto the groove
- 2) For typical PCB application we recommend to use VARTA-Mempac batteries
- 3)* For reference only

No.	Alterations:	Date:	Name:	Dimensions in mm	Material:
				Tolerance: DIN 7168 Medium	Refer to part list no: 070919
				Projection:	Description: 3/V150H battery with shrink sleeve & solder tags
				Scale: 2 : 1	
				Date: Name:	
				Prepared: 1997-09-19 C.Y.LEE	
				Approved: 2000-	

RIGHTS RESERVED TO MAKE TECHNICAL CHANGES, AS A RESULT OF FURTHER DEVELOPMENT, WITHOUT NOTICE . THIS DRAWING IS THE PROPERTY OF VARTA BATTERIES PTE LTD AND MUST NOT BE COPIED OR DISCLOSED TO A THIRD PARTY WITHOUT THE WRITTEN CONSENT OF VARTA BATTERIES PTE LTD.



Dwg. No:	070919	400
VKB Order No:	55615 303 059	
Orig No:		